

# GRADE 10 POWER MECHANICS NOTES

## SUBJECT GENERAL LEARNING OUTCOMES

By the end of Senior School, the learner should be able to:

1. Attain a firm foundation for career growth, further training and education in power mechanics related areas of study.
2. Utilise acquired power mechanics competencies to service and repair vehicle systems.
3. Apply acquired drawing skills to interpret and communicate engineering designs using information and communication technology where applicable.
4. Relate positively with members of the society during visits to work environment.
5. Use acquired knowledge to identify business opportunities related to power mechanics.
6. Appreciate the place of power mechanics in day-to-day life.

## **SUMMARY OF STRANDS AND SUB STRANDS**

### **1.0. FUNDAMENTALS OF POWER MECHANICS TECHNOLOGY**

- 1.1. Overview of Power Mechanics as a learning area
- 1.2. Evolution of automobile
- 1.3. Power mechanics workshop layout
- 1.4. General workshop rules and regulations

### **2.0 RELATED TECHNICAL DRAWING**

- 2 1. Diagonal scale
- 2 2. Loci
- 2 3. Tangency
- 2 4. Blending of lines and curve

### **3.0 VEHICLE SYSTEMS**

- 3.1 Road wheels
- 3.2 Vehicle body
- 3.3 Vehicle chassis
- 3.4 Vehicle body Joining processes

### **4.0 ENGINES**

- 4.1 Introduction to engines
- 4.2 Types of Engines
- 4.3 Classifications of Engine

## 1.0 Fundamentals of Power Mechanics

### 1.1 Overview of Power Mechanics as a Learning Area

#### a) Describing Power Mechanics as a Learning Area

Power mechanics is a broad field that deals with the study, maintenance, and repair of machines and engines that produce power. It encompasses a wide range of systems, including:

- **Internal Combustion Engines:** Found in cars, trucks, motorcycles, generators, and other equipment.
- **Power Transmission Systems:** Gears, belts, chains, and other components that transfer power from the engine to the wheels or other working parts.
- **Hydraulic and Pneumatic Systems:** Use fluids or air under pressure to perform work, seen in construction equipment and industrial machinery.
- **Electrical Systems:** Wiring, batteries, and electronic controls that power and regulate machines.
- **Agricultural Machinery:** Tractors, harvesters, and other equipment used in farming.
- **Marine Engines:** Powering boats and ships.

**Image: An image of a car engine bay, showing various components.**



#### b) Identifying Career Opportunities in Power Mechanics Field

Power mechanics offers a diverse range of career paths, including:

- **Automotive Technician:** Diagnosing and repairing vehicles.

Get more resources from [Enovate.co.ke](https://www.enovate.co.ke)

- **Diesel Mechanic:** Specializing in diesel engines used in trucks, buses, and heavy equipment.
- **Agricultural Equipment Mechanic:** Maintaining and repairing farm machinery.
- **Marine Mechanic:** Working on boat and ship engines.
- **Heavy Equipment Mechanic:** Repairing construction and industrial machinery.
- **Power Generation Technician:** Maintaining and repairing generators and power plants.
- **Small Engine Mechanic:** Fixing lawnmowers, chainsaws, and other small engines.
- **Parts Specialist:** Supplying necessary parts for repairs.
- **Service Manager:** Overseeing repair operations.
- **Sales of power equipment.**
- **Instruction in Technical institutions.**



Collage of different power mechanics professionals at work.

### c) Evaluating Activities Related to Power Mechanics in the Locality

To evaluate local power mechanics activities, learners can:

- **Visit local garages and workshops:** Observe the types of repairs being performed and the equipment used.
- **Explore agricultural areas:** Identify the types of machinery used and how they are maintained.
- **Investigate local industries:** Determine the power-driven equipment used in manufacturing and production.
- **Interview local mechanics:** Gather insights into their work, challenges, and opportunities.
- **Identify local businesses that sell or repair power equipment.**
- **Observe the use of generators and other power equipment in local businesses and homes.**

## d) Acknowledging the Importance of Power Mechanics as a Learning Area

Power mechanics is crucial for:

- **Transportation:** Maintaining vehicles that move people and goods.
- **Agriculture:** Ensuring the efficient operation of farm machinery for food production.
- **Industry:** Powering the machines that drive manufacturing and construction.
- **Power Generation:** Maintaining generators for electricity supply.
- **Economic Development:** Creating jobs and supporting businesses.
- **Improving Quality of Life:** Powering machines that make daily tasks easier.
- **Emergency services:** Ensuring that ambulances, fire engines, and other emergency vehicles are in working order.

### How is power mechanics important in day to day life?

- ❖ Power mechanics is essential in our daily lives because it ensures the functionality of various machines that we rely on.
- ❖ From cars and motorcycles that transport us to work and school, to generators that provide electricity during power outages, and agricultural equipment that produces our food, power mechanics plays a crucial role in keeping our world running smoothly.
- ❖ It is also important in the maintenance of water pumps, and other essential equipment.

### Learner Activities:

- **Online/Print Resources:** Use the internet and textbooks to research the definition and scope of power mechanics.
- **Brainstorming:** Discuss career opportunities in power mechanics with classmates.
- **Local Exploration:** Visit local workshops and industries to observe power mechanics activities.
- **Resource Person:** Invite a local mechanic or power mechanics professional to speak to the class.

## 1.2. Evolution of an Automobile

### Suggested Learning Experiences:

- **Brainstorming:** Begin with a class discussion about what learners already know about the history of cars.

Get more resources from [Enovate.co.ke](http://Enovate.co.ke)

- **Digital/Print Resources:** Use the internet, books, and documentaries to research the key milestones in automobile development.
- **Trend Analysis:** Identify and discuss the major trends that have shaped automobile design and technology (e.g., steam power, internal combustion, electric vehicles, autonomous driving).
- **Innovation Discussion:** Analyze how specific innovations (e.g., the assembly line, anti-lock brakes, hybrid engines) have impacted the automotive industry.
- **Reflection:** Conduct a reflective exercise on how the evolution of the automobile has affected society and daily life.

### a) Evolution of the Automobile Globally:

- **Early Beginnings:**
  - The concept of self-propelled vehicles dates back to the 17th and 18th centuries with steam-powered carriages.
  - Nicolas-Joseph Cugnot's steam-powered tricycle (1769) is often considered the first automobile.
  - Image: an image of Nicolas-Joseph Cugnot's steam-powered tricycle.

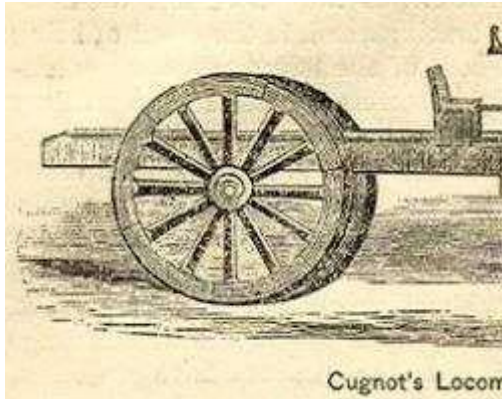

- **The Internal Combustion Engine:**
  - Karl Benz and Gottlieb Daimler are credited with independently developing the first gasoline-powered automobiles in the late 19th century.
  - Image: An image of Karl Benz's Patent-Motorwagen.



- **Mass Production:**

- Henry Ford's introduction of the assembly line in the early 20th century revolutionized automobile production, making cars more affordable. 📷 Image: An image of Henry Ford's assembly line.



- **Mid-20th Century Developments:**

- Post-World War II saw advancements in design, performance, and safety. 📷 The rise of the automotive industry in countries like Japan and Germany.

- **Modern Era:**

- The late 20th and 21st centuries have witnessed the rise of electronic controls, hybrid and electric vehicles, and autonomous driving technology.

## **b) Trends in Historical Developments:**

- **Power Source:** Steam, gasoline, diesel, electric, and hybrid.
- **Design and Aerodynamics:** From boxy shapes to streamlined designs.
- **Safety Features:** Brakes, seat belts, airbags, and electronic stability control.

- **Comfort and Convenience:** Air conditioning, power steering, and entertainment systems.
- **Technology:** Engine management systems, GPS navigation, and advanced driver-assistance systems (ADAS).
- **Environmental Concerns:** Increased focus on fuel efficiency and emissions reduction.

#### **c) Importance of Innovation:**

- Innovation has driven improvements in performance, safety, and efficiency.
- It has led to the development of new technologies that have transformed the automotive industry.
- Innovation is crucial for addressing future challenges, such as climate change and traffic congestion.
- Innovation has also increased the comfort and reliability of automobiles.

#### **d) Appreciation of the Evolution:**

- The evolution of the automobile has had a profound impact on society, transforming transportation, commerce, and lifestyle.
- It has created countless jobs and industries.
- Understanding the history of the automobile helps us appreciate its significance and the challenges and opportunities that lie ahead.

#### **Suggested Key Inquiry Questions:**

- **How has technology advancement affected power mechanics?**
  - This question encourages learners to think about how changes in automobile technology (e.g., electronic controls, electric vehicles) have altered the work of mechanics.
- **What were the key factors that led to the mass production of automobiles?**
  - This question encourages the research of the socio-economic factors that allowed automobiles to become available to the masses.
- **How have safety regulations and environmental concerns influenced automobile design?**
  - This encourages research into the regulations that influence modern vehicle design.
- **What are the potential future trends in automobile development?**

- This encourages thought about the future of the automotive industry.
- **How did world events influence the development of automobiles?**
  - This question encourages the thought of how events such as world wars

influenced the development of cars. **1.3. Power Mechanics Workshop Layout**

### Suggested Learning Experiences:

- **Online/Print Resources:** Research the various areas of a power mechanics workshop using the internet, textbooks, and technical manuals.
- **Brainstorming:** Discuss the different sections of a workshop and their functions.
- **Workshop Observation:** If possible, visit a local power mechanics workshop to observe the layout and organization.
- **Illustration/Sketching:** Create diagrams and sketches of a standard power mechanics workshop layout.
- **Importance Discussion:** Discuss the importance of each workshop area and how they contribute to efficient work.
- **Reflection:** Reflect on the importance of an organized workshop layout for safety and productivity.

### a) Identifying Main Areas in a Power Mechanics Workshop:

- **Work Area/Repair Bays:** Where vehicles and machinery are repaired. 📷 Image: An image of a car inside of a repair bay.



- **Tool Storage Area:** For organized storage of tools and equipment. 📷 Image: An image of a well organized tool storage area.



- **Parts Storage Area:** For storing spare parts and components.

📷 Image: An image of a parts storage area with shelves full of parts.



parts storage area with shelves full of parts.

- **Work Benches:** For performing various tasks and repairs. 📷 Image: An image of a work bench with tools on top.



- **Office/Reception Area:** For administrative tasks, customer interaction, and record-keeping.

Image: An image of an office located inside of a workshop.



- **Passageways/Traffic Flow:** Clear pathways for safe movement of people and equipment.
- **Welding Area (if applicable):** A designated area for welding and fabrication.
- **Machining Area (if applicable):** Area for using lathes, milling machines, and other machine tools.
- **Cleaning Area:** For cleaning parts and equipment.
- **Waste Disposal Area:** For safe disposal of waste materials.
- **Engine Overhaul Area:** A designated area for engine repairs.
- **Testing Area:** Area for testing repaired vehicles and components.

## b) Sketching a Layout of Main Areas

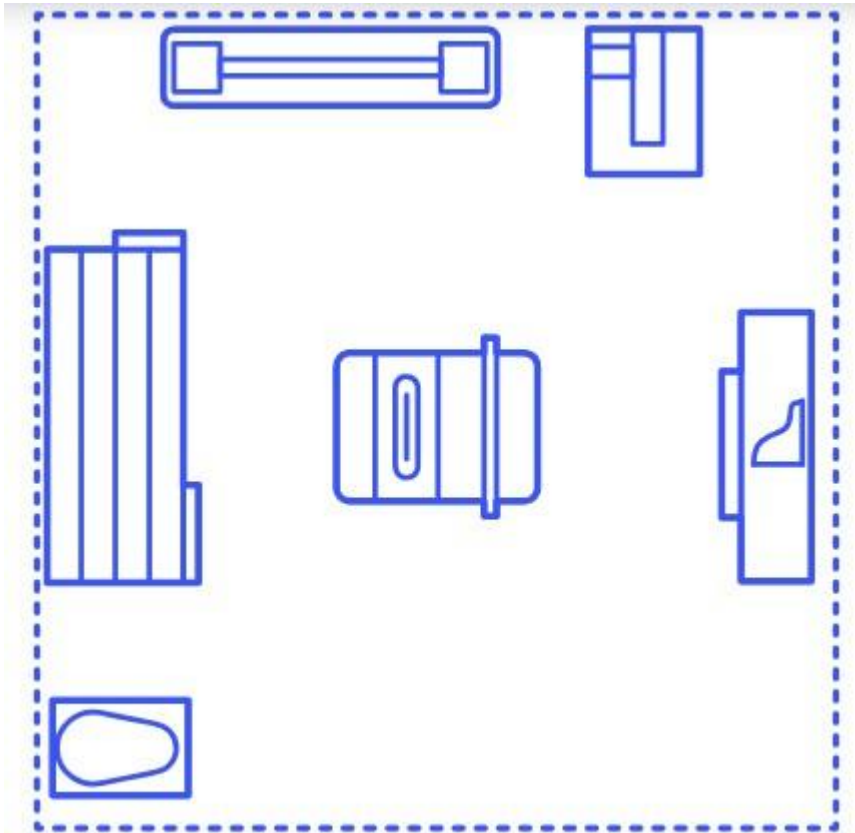

- Learners should be able to create a scaled drawing of a workshop, showing the placement of each area.
- The layout should consider safety, efficiency, and workflow.
- The layout should include the placement of large equipment such as vehicle lifts, and engine stands.

## c) Exploring the Importance of the Workshop Areas:

- **Efficiency:** A well-organized workshop minimizes wasted time and movement.
- **Safety:** Designated areas reduce the risk of accidents and injuries.
- **Organization:** Proper storage and organization of tools and parts improve productivity.
- **Professionalism:** A clean and organized workshop creates a positive impression on customers.
- **Specialized Tasks:** Designated areas for specific tasks (e.g., welding, machining) improve the quality of work.
- **Proper traffic flow:** Allows for the easy movement of vehicles and people.

#### **d) Appreciating the Importance of the Workshop Layout:**

- A well-planned workshop layout is essential for the smooth operation of a power mechanics business.
  - It contributes to the safety and well-being of workers.
  - It enhances the quality of repairs and services. ☐ It increases the productivity of the mechanics.
- #### **1.4. General Workshop Rules and Regulations**

#### **Suggested Learning Experiences:**

- **Brainstorming:** Begin with a class discussion about potential hazards in a workshop and how to prevent them.
- **Digital/Print Resources:** Research safety rules, regulations, and best practices using the internet, manuals, and safety guides.
- **Video Observation:** Watch videos demonstrating workshop safety signs and their meanings.
- **PPE Demonstration and Practice:** Demonstrate the proper use of various types of PPE and provide opportunities for learners to practice.
- **Practical Application:** Practice following safety rules in a workshop setting.

#### **a) Describing General Safety Rules and Regulations:**

##### **☐ General Rules:**

- Keep the workshop clean and organized.
- No running or horseplay.
- Report any accidents or hazards immediately.
- Use tools and equipment only for their intended purpose.
- Never work under a vehicle supported only by a jack. Use jack stands.
- Be aware of fire hazards and know the location of fire extinguishers.
- Handle chemicals and fluids with care.
- Keep passageways clear.
- Properly dispose of waste materials.

##### **☐ Equipment Specific Rules:**

- Always disconnect power tools before making adjustments.
- Use proper lifting techniques.

- Wear appropriate PPE when using power tools, welders, or other hazardous equipment.
- Follow manufacturer's instructions for all equipment.
- Image: an image of a person using a jack stand to support a vehicle.



## b) Interpreting Workshop Safety Signs:

### 📄 Prohibitive Signs:

- 📄 Red circle with a diagonal line indicating actions that are not allowed (e.g., "No Smoking," "No Open Flames").



### 📄 Warning Signs:

- Yellow triangle with a black exclamation mark or symbol indicating potential hazards (e.g., "Caution: Hot Surface," "Warning: High Voltage").
- Image: an image of a high voltage warning sign.

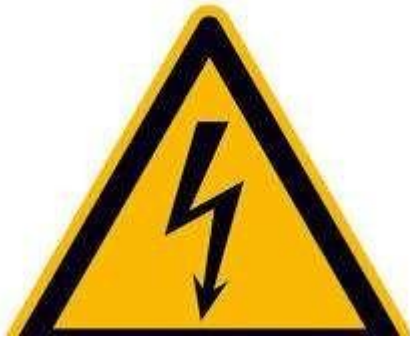

### 🔍 **Mandatory Signs:**

- Blue circle that indicates actions that must be taken. Example, wear safety glasses.
- Image: an image of a wear safety glasses sign.



### 🔍 **Emergency Signs:**

- Green square or rectangle that indicates the location of safety equipment or first aid.
- Image: an image of a first aid sign.



## c) Practicing Safe Use of Personal Protective Equipment (PPE):

### 🔍 **Types of PPE:**



- Safety glasses/goggles: To protect eyes from flying debris and chemicals.
- Earplugs/earmuffs: To protect hearing from loud noises.
- Gloves: To protect hands from chemicals, sharp objects, and heat.
- Safety shoes/boots: To protect feet from falling objects and spills.
- Respirators/masks: To protect lungs from dust, fumes, and vapors.
- Overalls/coveralls: To protect clothing and skin from dirt, grease, and chemicals.
- Face shields: to protect the face from flying debris and chemical splashes.

#### **🔍 Proper Use:**

- Ensure PPE fits properly.
- Inspect PPE for damage before use.
- Use the correct PPE for the task.
- Clean and maintain PPE regularly.

#### **d) Appreciating the Need for Safety:**

- Safety is paramount in a power mechanics workshop to prevent injuries and accidents.
- Following safety rules protects both the individual and others in the workshop.
- A safe work environment promotes productivity and efficiency.
- Safety is a legal and ethical responsibility.

# STRAND 2.0: RELATED DRAWING

## 2.1. Scales

### Suggested Learning Experiences:

- **Online/Print Resources:** Research diagonal scales using the internet, textbooks, and technical drawing manuals.
- **Procedure Discussion:** Discuss the step-by-step process of constructing a diagonal scale.
- **Practical Drawing:** Provide opportunities for learners to practice constructing diagonal scales.
- **Interpretation Brainstorming:** Discuss how to interpret measurements from a diagonal scale.
- **Real-Life Application Discussion:** Explore how scales are used in various real-world scenarios.

### a) Describing Diagonal Scale:

- A diagonal scale is a graphical measuring device used in technical drawing to represent very small measurements with high accuracy.
- It allows for the measurement of lengths to a greater degree of precision than a standard ruler.
- It uses the principle of dividing a small length into a number of equal parts by means of parallel lines and diagonal lines.  Image: An image of a diagonal scale.

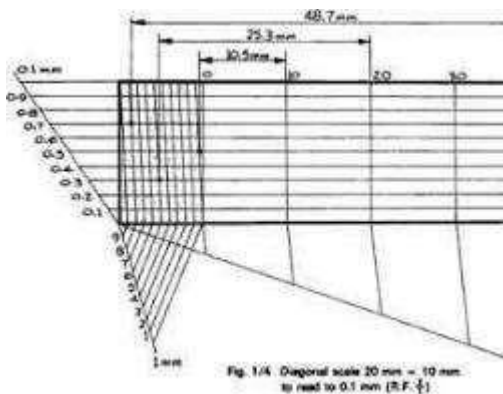

### b) Constructing Diagonal Scale:

#### Steps:

Get more resources from [Enovate.co.ke](http://Enovate.co.ke)

1. Draw a line representing the main unit of the scale.
2. Divide this line into the required number of primary divisions.
3. Construct perpendicular lines at the endpoints of the main unit line.
4. Divide the perpendicular lines into the required number of secondary divisions.
5. Draw diagonal lines connecting the division points.
6. Mark the scale with appropriate units and divisions.

Learners should practise drawing scales with different measurements.

### c) Interpreting Diagonal Scale:

- To interpret a measurement on a diagonal scale, locate the primary and secondary divisions corresponding to the desired length.
- Use the diagonal lines to determine the precise measurement.
- Learners should practise reading different measurements from pre-drawn diagonal scales.

### d) Appreciating the Application of Diagonal Scale in Real Life:

#### Applications:

- **Engineering Drawings:** For precise measurements in machine parts and structures.
- **Architectural Drawings:** For detailed plans and elevations.
- **Map Making:** For accurately representing distances and features.
- **Scientific Instruments:** For precise measurements in experiments.
- **Tool and die making:** For the very precise measurements needed to create tools.

Scales allow for the accurate representation of large objects on small pieces of paper and visa versa.

## 2.2. Loci

### Suggested Learning Experiences:

- **Online/Print Resources:** Research the definition and types of loci using the internet, textbooks, and technical drawing manuals.
- **Type Description:** Discuss the characteristics and properties of various types of loci.
- **Practical Drawing:** Provide opportunities for learners to practice constructing different types of loci (ellipse, cycloid, involute, parabola, hyperbola).

- **Mechanism Locus Discussion:** Discuss the procedure for drawing the locus of a point on a mechanism.
- **Mechanism Locus Practice:** Practice drawing the locus of a point on 2-link and 3-link mechanisms.
- **Application Discussion:** Explore the applications of loci in power mechanics.

#### a) Defining a Locus:

- A locus is the path traced by a point moving according to a given rule or set of conditions.
- In technical drawing, it refers to the set of all points that satisfy a specific geometric requirement.
- Image: an image showing a point moving along a path to create a locus.

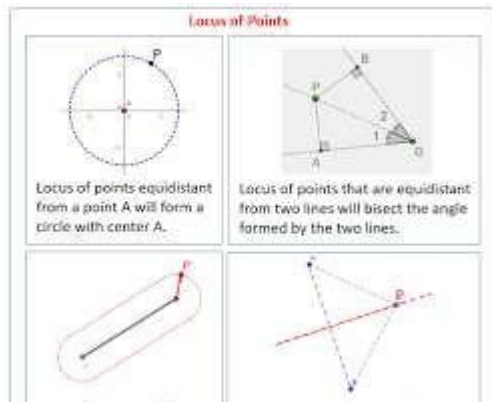

#### b) Describing Types of Locus:

- **Ellipse:**
  - The locus of a point that moves so that the sum of its distances from two fixed points (foci) is constant.
  - Image: an image of an ellipse.

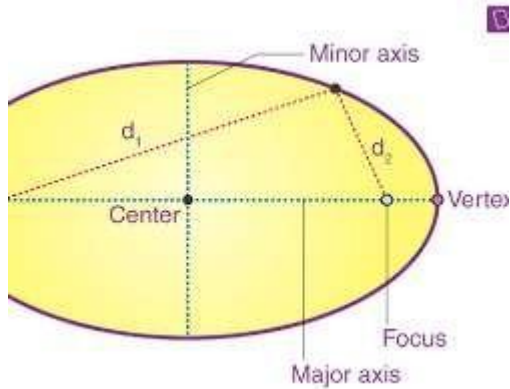

• **Cycloid:**

- The locus of a point on a circle as the circle rolls along a straight line.
- Image: an image of a cycloid.

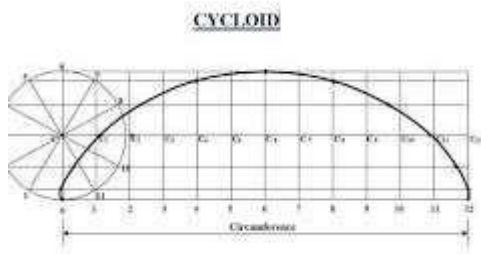

• **Involute:**

- The locus of a point on a taut string as it unwinds from around a circle or other curve.
- Image: an image of an involute.

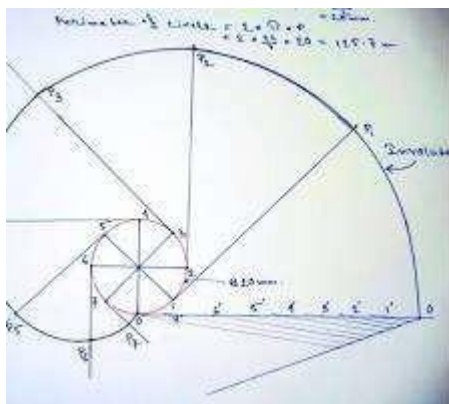

• **Parabola:**

- The locus of a point that moves so that its distance from a fixed point (focus) is equal to its distance from a fixed line (directrix). Image: an image of a parabola.

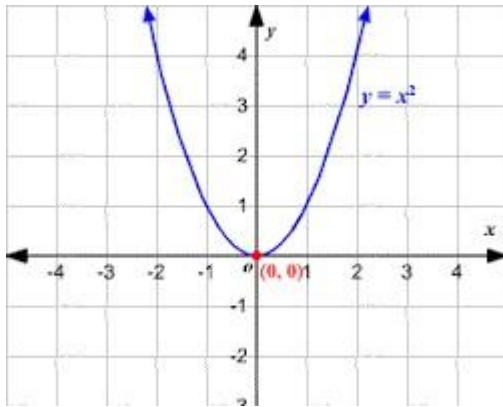

- **Hyperbola:**

The locus of a point that moves so that the difference of its distances from two fixed points (foci) is a constant. □ Image: an image of a hyperbola.

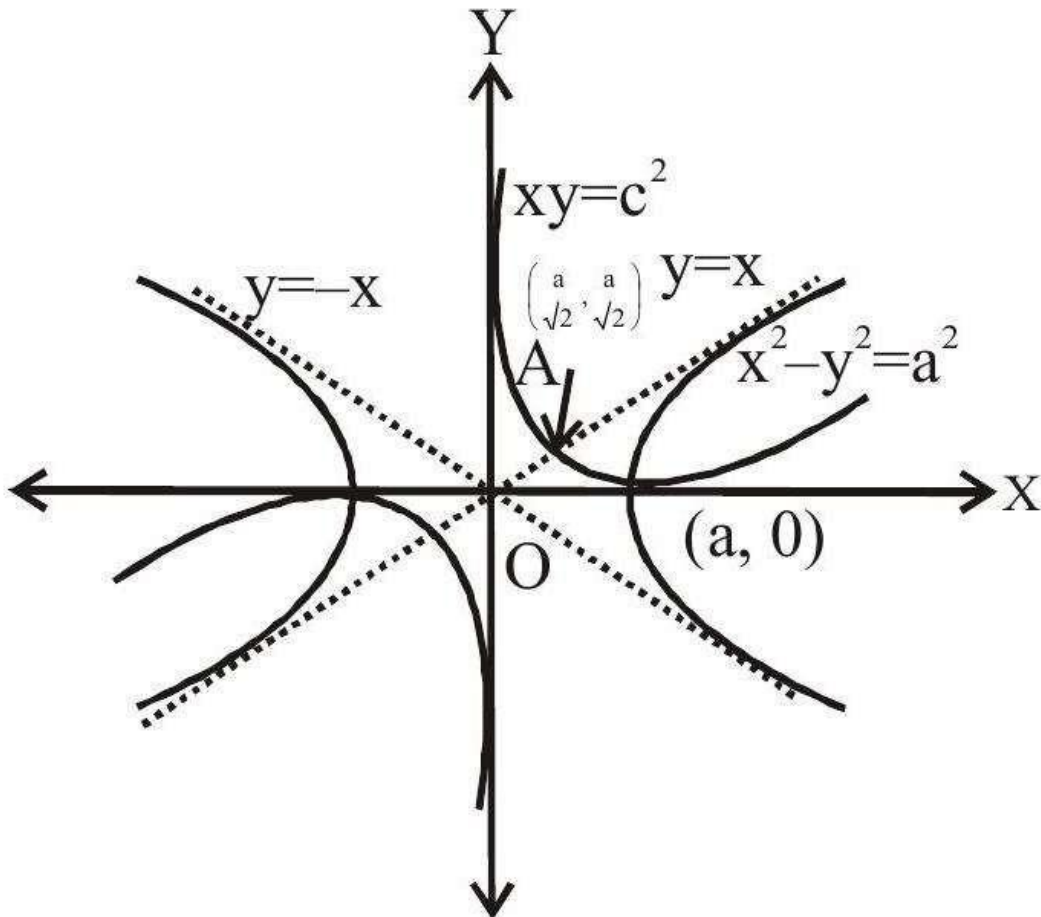

**c) Constructing Different Types of Locus:**

- Learners should practice the standard methods for constructing each type of locus using compass, ruler, and other drawing tools.
- Learners should understand the mathematical principles behind each locus.

#### **d) Constructing the Locus of Link Mechanisms:**

- Link mechanisms involve the movement of connected links, and the locus of a point on a link describes its path.
- **2-Link Mechanism:**
  - Consists of two links connected by a pivot.
  - The locus of a point on one of the links will be a circle or a portion of a circle.
- **3-Link Mechanism:**
  - Consists of three links connected by pivots.
  - The locus of a point on one of the links can be a more complex curve.

Learners should practise drawing the locus of points on simple 2 and 3 link mechanisms.

#### **e) Appreciating the Application of Loci in Power Mechanics:**

- **Mechanism Design:** Understanding loci is essential for designing and analyzing the movement of mechanical systems.
- **Cam Design:** Loci are used to design the profiles of cams, which control the movement of valves and other components.
- **Gear Design:** Involutés are used in the design of gear teeth to ensure smooth and efficient power transmission.
- **Engine Analysis:** Loci can be used to analyze the movement of pistons and other engine components.
- **Robotics:** Loci are used in the design of robotic arms and other articulated systems.
- **Suspension systems:** Loci are used to design and analyze the movement of vehicle suspension systems.

### **2.3. Tangency**

#### **Suggested Learning Experiences:**

- **Online/Print Resources:** Research tangency concepts and construction methods using the internet, textbooks, and technical drawing manuals.

- **Method Discussion:** Discuss the principles and procedures involved in constructing tangents.
- **Practical Drawing (Point to Circle):** Practice drawing tangents from a given point to a circle.
- **Practical Drawing (External Tangents):** Practice constructing external tangents to two circles (both equal and unequal).
- **Practical Drawing (Internal Tangents):** Practice constructing internal tangents to two circles (both equal and unequal).
- **Importance Discussion:** Explore the applications and significance of tangency in technical drawing.

#### a) Describing Methods of Constructing Tangents:

- A tangent is a line that touches a curve (usually a circle) at only one point.
- The tangent is perpendicular to the radius of the circle at the point of tangency.
- Methods include:
  - Construction using perpendicular bisectors.
  - Construction using similar triangles. □ Construction using arcs and lines.

#### b) Constructing a Tangent to a Circle from a Point:

- Given a circle and a point outside the circle, the task is to draw a line from that point that touches the circle at only one point.
- Steps include:
  - Joining the point to the center of the circle.
  - Constructing a semicircle with this line as the diameter.
  - Finding the intersection point of the semicircle and the circle.
  - Drawing the tangent line from the given point to the intersection point.
- Image: a step by step image showing how to draw a tangent from a point to a circle.

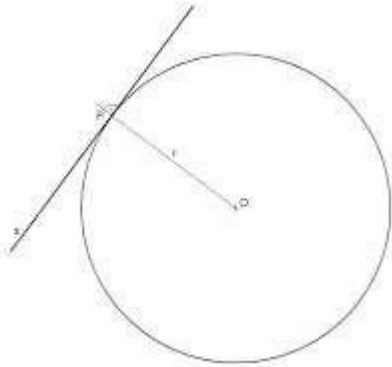

how to draw a tangent from a point to a circle.

### c) Constructing External Tangents to Two Circles:

- External tangents are lines that touch both circles on the same side.
- Steps include:
  - Constructing a circle with a radius equal to the difference of the radii of the two given circles.
  - Drawing a tangent from the center of the larger circle to the constructed circle.
  - Drawing parallel lines.
- Image: a step by step image showing how to draw external tangents to two circles.

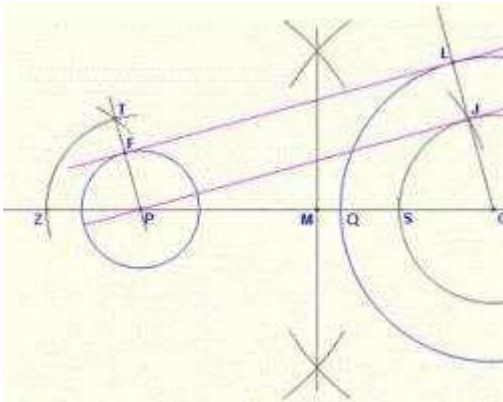

how to draw external tangents to two circles.

### d) Constructing Interior Tangents to Two Circles:

- Interior tangents are lines that touch both circles on opposite sides.
- Steps include:
  - Constructing a circle with a radius equal to the sum of the radii of the two given circles.



- **Shape Construction:** Practice constructing various shapes using blending techniques.
- **Application Brainstorming:** Discuss the applications of blending in power mechanics.

#### a) Describing Blending of Lines and Arcs:

- Blending is the process of smoothly connecting lines and curves using arcs.
- It is used to create smooth transitions and avoid sharp corners in technical drawings.
- Blending ensures that the resulting shape is continuous and aesthetically pleasing.

#### b) Constructing Arcs that Blend Lines:

- **Blending Two Straight Lines:**
  - ✓ Draw the two straight lines.
  - ✓ Determine the radius of the blending arc.
  - ✓ Construct arcs from points on the lines to find the center of the blending arc.
  - ✓ Draw the blending arc.
- **Blending a Straight Line and a Circle:**
  - ✓ Draw the straight line and the circle.
  - ✓ Determine the radius of the blending arc.
  - ✓ Construct arcs from points on the line and circle to find the center of the blending arc.
  - ✓ Draw the blending arc.
- Image: Step by step images of blending two lines, and a line with a circle.

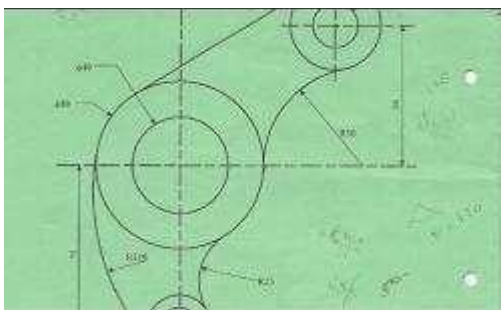

#### c) Constructing Arcs that Blend Two Circles:

- **Blending Two Equal Circles (External):**
  - ✓ Draw the two equal circles.
  - ✓ Determine the radius of the blending arc.

- ✓ Construct arcs from the centers of the circles to find the center of the blending arc.
- ✓ Draw the blending arc.
- **Blending Two Equal Circles (Internal):**
  - ✓ Draw the two equal circles.
  - ✓ Determine the radius of the blending arc.
  - ✓ Construct arcs from the centers of the circles to find the center of the blending arc.
  - ✓ Draw the blending arc.
- Image: Step by step images of blending two equal circles externally and internally.

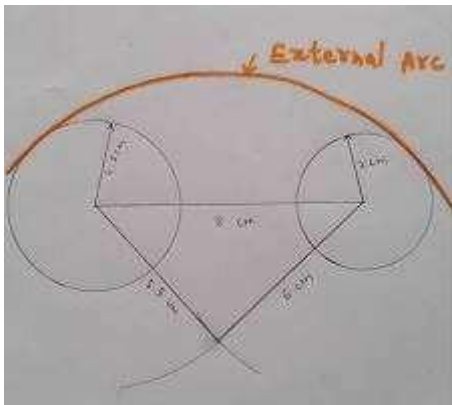

#### d) Using Blending to Construct Given Shapes:

- Practice constructing various shapes, such as rounded rectangles, fillets, and other complex shapes, using blending techniques.
- This involves combining the knowledge of blending lines and circles to create more elaborate shapes.

#### e) Appreciating the Application of Blending in Power Mechanics:

- **Applications:**
  - **Engine Components:** Blending is used to create smooth transitions in engine parts, such as connecting rods and crankshafts.
  - **Vehicle Body Panels:** Blending ensures smooth contours and aerodynamic shapes in vehicle body panels.
  - **Gear Design:** Blending is used to create smooth transitions between gear teeth profiles.
  - **Pipe Fittings:** Blending is used to create smooth bends in pipes and fittings.

- **Tool Design:** Blending is used to create ergonomic and comfortable tool handles.
- **Bearing design:** Blending is used to create smooth transitions within bearing races.
- Blending improves the strength, durability, and performance of mechanical components.
- It reduces stress concentrations and improves fluid flow.
- It also improves the aesthetic appeal of the final product.

## STRAND 3.0: VEHICLE SYSTEMS

### 3.1. Road Wheels

#### Suggested Learning Experiences:

- **Digital/Print Resources:** Research the functions of wheels and tire specifications using the internet, textbooks, and automotive manuals.
- **Brainstorming:** Discuss the different types of tires and their characteristics.
- **Sketching:** Draw illustrations of radial and cross-ply tire construction.
- **Tire Specification Analysis:** Analyze and interpret tire sidewall markings.
- **Discussion:** Reflect on the importance of tires for vehicle safety and performance.

#### a) Explaining the Functions of Wheels in a Vehicle:

- **Support Vehicle Weight:** Wheels carry the weight of the vehicle and its occupants/cargo.
- **Provide Traction:** Tires provide the necessary grip for acceleration, braking, and cornering.

- **Absorb Road Shocks:** Tires and wheels help absorb bumps and irregularities in the road surface.
- **Facilitate Steering:** Wheels allow the driver to control the direction of the vehicle.
- **Enable Movement:** Wheels, in conjunction with the power train, allow the vehicle to move.

## b) Identifying Types of Tires Used in Vehicles:

### 📌 Tube Tires:

- ✓ Use an inner tube to hold air.
- ✓ Older technology, less common in modern vehicles.
- ✓ Image: an image of a tube tire, with the inner tube shown.



### Tubeless Tires:

- ✓ Do not use an inner tube.
- ✓ Air is contained between the tire and the wheel rim.
- ✓ More common in modern vehicles due to improved safety and reliability. 📌 Image: an image of a tubeless tire on a rim.



### c) Illustrating Types of Ply Orientation Used on Vehicle Tires:

#### Radial Ply:

- ✓ Plies run radially from bead to bead, with stabilizing belts running circumferentially.
- ✓ Provides better ride quality, handling, and fuel efficiency.
- ✓ Image: an image of a radial ply tire cross section.

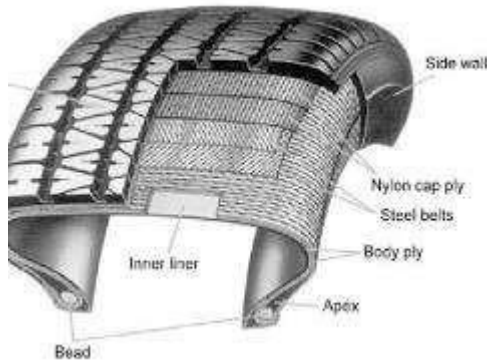

#### Cross Ply (Bias Ply):

- ✓ Plies run diagonally across each other.
- ✓ Stronger sidewalls, suitable for heavy-duty applications. □ Image: an image of a cross ply tire cross section.

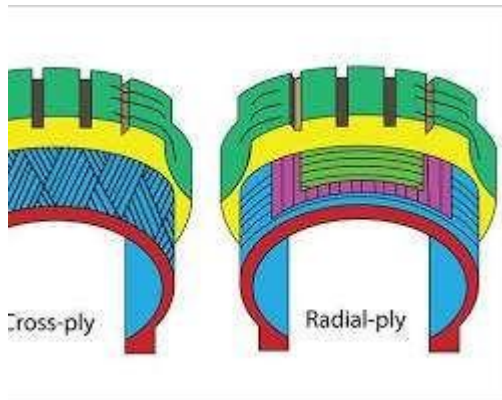

### d) Interpreting Specifications on Tire Side Walls:

#### Tire Size: (e.g., 205/55R16)

- 205: Section width in millimeters.
- 55: Aspect ratio (sidewall height as a percentage of section width).
- R: Radial construction.

- 16: Rim diameter in inches.

**Load Capacity:**

- ❓ Indicates the maximum weight the tire can carry.

**Speed Rating:**

- ❓ Indicates the maximum speed the tire is designed for.

**Tire Type:**

- Indicates the intended use of the tire. (e.g. P for passenger vehicle, LT for light truck)

**Tire Width:**

- The measurement of the tire from sidewall to sidewall.

**e) Appreciating the Role of Tires in Vehicle Operations:**

- Tires are critical for vehicle safety, performance, and comfort.
- Proper tire maintenance is essential for safe vehicle operation.
- Understanding tire specifications helps in selecting the correct tires for a vehicle.
- Tires allow for the transfer of the vehicles power to the road.

**3.2. Vehicle Body**

**Suggested Learning Experiences:**

- **Brainstorming:** Discuss the various roles and purposes of a vehicle's body.
- **Digital/Print Resources:** Research different vehicle body types using the internet, textbooks, and automotive resources.
- **Local Exploration:** Visit local garages, car dealerships, or observe vehicles in the community to identify interior body parts.
- **Visual Aids:** Use diagrams, illustrations, and photographs to identify exterior body parts.
- **Discussion:** Reflect on the importance of the vehicle body for safety, comfort, and functionality.

**a) Describing the Functions of a Body in a Vehicle:**

- **Protection:** Protects occupants from weather, impacts, and debris.
- **Support:** Provides structural support for the vehicle's components.
- **Comfort:** Creates a comfortable and ergonomic environment for occupants.
- **Aesthetics:** Contributes to the vehicle's visual appeal and design.
- **Cargo/Passenger Space:** Provides space for passengers and cargo.

- **Aerodynamics:** Contributes to the vehicle's aerodynamic efficiency.

## b) Explaining the Types of Bodies Used in Vehicles:

### Saloon (Sedan):

- ✓ Typically a four-door vehicle with a separate trunk.
- ✓ Image: An image of a sedan car.



### • Station Wagon (Estate):

- ✓ An extended body with a rear cargo area. 📷 Image: An image of a station wagon car.



### • Convertible:

- ✓ A vehicle with a retractable roof.
- ✓ Image: An image of a convertible car.



- **Van:**

- ✓ A large, enclosed vehicle for transporting goods or passengers.
- ✓ Image: An image of a van vehicle.



- **Pickup:**

- ✓ A vehicle with an open cargo bed.
- ✓ Image: An image of a pickup truck.



- **Bus:**

- ✓ A large vehicle designed to carry many passengers. 📄 Image: An image of a bus.



bus.

## Lorries



## Armored vehicles



### c) Identifying Interior Body Parts of a Vehicle:

- ✓ **Seats:** Provide seating for occupants.
- ✓ **Floor:** Provides a flat surface for occupants and cargo.
- ✓ **Roof:** Protects occupants from weather.
- ✓ **Doors:** Allow entry and exit.
- ✓ **Handles:** Used to open and close doors.
- ✓ **Dashboard:** Houses instruments and controls.
- ✓ **Steering wheel:** Used to steer the vehicle.
- ✓ **Interior trim:** The materials used to finish the interior of the vehicle.

### d) Illustrating Exterior Body Parts of a Vehicle:

- ✓ **Bumpers:** Protect the vehicle from minor impacts.
- ✓ **Fenders (Wings):** Protect the wheels and prevent debris from splashing.
- ✓ **Roof:** Protects occupants from weather.
- ✓ **Bonnet (Hood):** Covers the engine compartment.
- ✓ **Sills (Rocker Panels):** Provide structural support along the bottom of the vehicle.
- ✓ **Doors:** Allow entry and exit.
- ✓ **Boot (Trunk):** Provides cargo space.
- ✓ **Side Wings (Quarter Panels):** The body panels located behind the rear doors.
- ✓ **Windshield/windows:** Allows visibility.
- ✓ **Headlights/taillights:** Provides visibility at night and signals to other drivers.

### e) Appreciating the Importance of Bodies in Vehicles:

- The vehicle body is essential for safety, comfort, and functionality.
- It plays a crucial role in protecting occupants and cargo.

- The body also contributes to the vehicle's performance and efficiency.
- The vehicle body style also greatly effects the use case of a vehicle.

### 3.3. Chassis

#### Suggested Learning Experiences:

- **Print Resources:** Research different types of chassis using textbooks, automotive manuals, and technical documents.
- **Local Observation:** Visit local garages or vehicle repair shops to observe different chassis types.
- **Peer Discussion:** Discuss the functions and importance of the chassis with classmates.
- **Sketching:** Draw illustrations of various types of frames used in chassis construction.

#### a) Describing Types of Chassis Used on Vehicles:

##### Separate Chassis (Ladder Frame):

- ✓ A separate frame structure that supports the body and other components.
- ✓ Commonly used in trucks and heavy-duty vehicles.
- ✓ Image: An image of a ladder frame chassis.



##### Integral Chassis (Unibody):

- ✓ The body and frame are integrated into a single structure.
- ✓ Commonly used in passenger cars and light vehicles. 📄 Image: An image of a unibody chassis.



- **Space Frame Chassis:**

- ✓ Uses a series of interconnected tubes to create a lightweight and rigid structure.
- ✓ Commonly used in high-performance and sports cars. 🖼️ Image: an image of a space frame chassis.



space frame chassis.

## **b) Explaining the Functions of a Chassis in a Vehicle:**

- **Structural Support:** Provides a rigid framework for mounting the engine, transmission, suspension, and other components.
- **Load Distribution:** Distributes the weight of the vehicle and its cargo evenly.
- **Impact Protection:** Helps protect occupants in the event of a collision.
- **Vibration Reduction:** Minimizes vibrations and noise from the engine and road.
- **Component Mounting:** Provides mounting points for various vehicle systems.

## **c) Illustrating Types of Frames Used in the Construction of Vehicle Chassis:**

- **Tube Frame:**

- ✓ Constructed from round or square tubes welded together.
- ✓ Lightweight and strong, used in racing and high-performance vehicles.

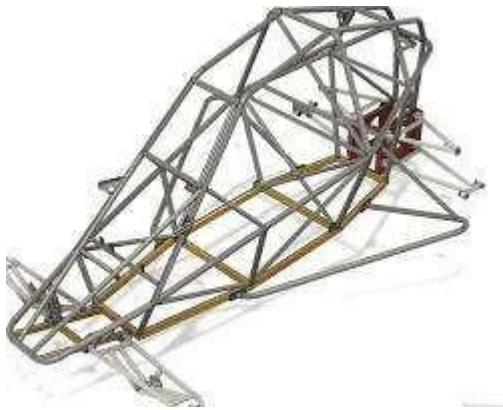

- **Channel Frame:**

- ✓ Constructed from C-shaped steel sections.
- ✓ Strong and relatively inexpensive, used in trucks and heavy-duty vehicles.



- **Box Frame:**

- ✓ Constructed from rectangular or square steel sections.
- ✓ Strong and rigid, used in trucks and heavy-duty vehicles.  Image: An image of a box frame.

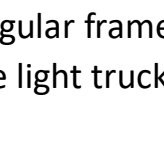

- **Flat Frame (Platform Frame):**

- ✓ A flat, rectangular frame used as a base for the vehicle body.
- ✓ Used in some light trucks and utility vehicles. 



**d) Appreciating the Role of a Vehicle Chassis:**

- The chassis is the foundation of the vehicle, providing structural integrity and support.
- It ensures the safety and stability of the vehicle.
- Different chassis types are designed for specific vehicle applications and load requirements.
- Understanding the chassis is essential for vehicle maintenance and repair. **3.4. Vehicle**

**Body Joining Processes**

**Suggested Learning Experiences:**

- **Online/Print Resources:** Research threaded fasteners, locking devices, riveting, and adhesives using the internet, textbooks, and automotive manuals.
- **Local Observation:** Visit local garages or body shops to observe different joining processes used on vehicles.

- **Visual Aids:** Use diagrams, illustrations, and videos to understand the principles of each joining process.
- **Practical Application:** Practice joining vehicle body parts using adhesives.
- **Terminology Research:** Research the definitions of terms related to adhesives (adhesive, bond, cohesion).

### a) Describing Threaded Fasteners Used in Vehicle Body Joining:

#### Bolts and Nuts:

- ✓ Used to join two or more parts together with a threaded fastener and a nut.
- ✓ Provide a strong and detachable connection.  Image: an image of bolts and nuts.



#### Screws:

- ✓ Used to join parts by threading into one of the parts.
- ✓ Various types, including self-tapping screws and machine screws.



### b) Illustrating Locking Devices Used in Vehicle Bodies:

Get more resources from [Enovate.co.ke](http://Enovate.co.ke)

### Cotter Pins:

- ✓ Used to secure nuts and bolts by preventing them from loosening.
- ✓ Inserted through a hole in the fastener and bent to lock it in place. 📄 Image: an image of a cotter pin.



cotter pin.

### Circlips (Snap Rings):

- ✓ Used to secure parts on a shaft or in a bore.
- ✓ Spring-loaded rings that snap into a groove.
- ✓ Image: an image of a circlip.



circlip.

### Split Pins:

- 📄 Similar to cotter pins, used to prevent fasteners from loosening. 📄 Image: an image of a split pin.

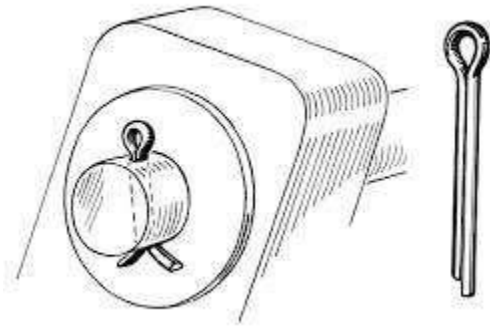

split pin.

### c) Illustrating Riveting as Applied in Vehicle Bodies:

#### Riveting Process:

- ✓ Joining two or more parts by inserting a rivet through holes in the parts and deforming the rivet to create a head.
- ✓ Provides a strong and permanent connection.
- ✓ Image: an image of a rivet and a riveter.



Rivet and a riveter.

#### Riveting Tools:

- ☐ Riveters, hammers, and dollies.

#### Applications:

- ☐ Joining body panels, trim, and other components.

### d) Performing Joining Processes on Vehicle Body Parts Using Adhesives:

#### Adhesive Types:

Get more resources from [Enovate.co.ke](http://Enovate.co.ke)

Epoxies, urethanes, and contact adhesives.

**Bonding Process:**

- ✓ Cleaning and preparing the surfaces.
- ✓ Applying the adhesive.
- ✓ Clamping or holding the parts together until the adhesive cures.

**Adhesive terms:**

- ✓ **Adhesive:** A substance used to join materials.
- ✓ **Bond:** The connection formed by the adhesive.
- ✓ **Cohesion:** The internal strength of the adhesive.

**e) Acknowledging the Role of Joining Processes in Vehicle Bodies:**

- Joining processes are essential for assembling and repairing vehicle bodies.
- They provide strong, durable, and reliable connections.
- Different joining processes are used for different applications and materials.
- Proper joining techniques are essential for vehicle safety and aesthetics.

# STRAND 4.0: ENGINES

## 4.1. Introduction to Engines

### Suggested Learning Experiences:

- **Online/Print Resources:** Research the definition of an engine using the internet, textbooks, and automotive manuals.
- **Peer Discussion:** Discuss the definition of an engine and its role in power mechanics.
- **Digital/Print Media Exploration:** Explore the various uses of engines in daily life.
- **Terminology Brainstorming:** Discuss the common terminologies used in engine technology.
- **Terminology Research:** Research the definitions of engine terminologies (bore, stroke, capacity, horsepower, TDC, BDC).
- **Measurement and Calculation:** Perform measurements and calculations to determine the capacity of a given engine.

### a) Defining an Engine as Used in Power Mechanics:

- An engine is a machine that converts thermal energy (heat) into mechanical work.
- In power mechanics, it specifically refers to devices that convert the chemical energy of fuel into mechanical energy.
- Image: An image of a typical internal combustion engine.

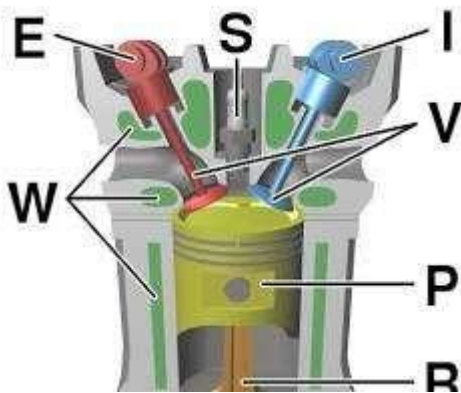

### b) Identifying Uses of Engines in Day-to-Day Life:

- **Transportation:** Cars, motorcycles, trucks, buses, trains, airplanes, ships.
- **Power Generation:** Generators for electricity.

- **Industrial Machinery:** Powering various machines in factories and construction.
- **Agriculture:** Tractors, harvesters, and other farm equipment.
- **Household Appliances:** Lawnmowers, chainsaws, and other small engines.
- **Emergency services:** Fire engines, ambulances, and other emergency vehicles.

### c) Explaining Terminologies Used in Engines:

🔍 **Bore:** The diameter of the cylinder.

🔍 Image: An image of a cylinder bore.

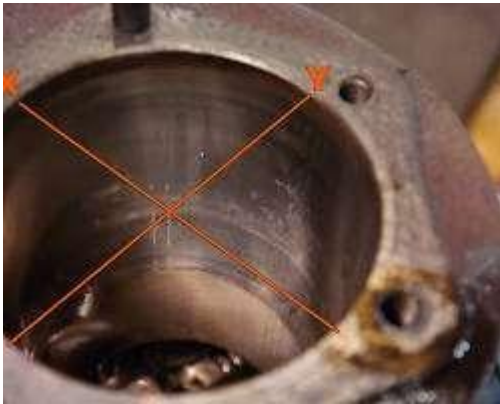

🔍 **Stroke:** The distance the piston travels from top dead center (TDC) to bottom dead center (BDC).

🔍 Image: An image of a piston stroke.

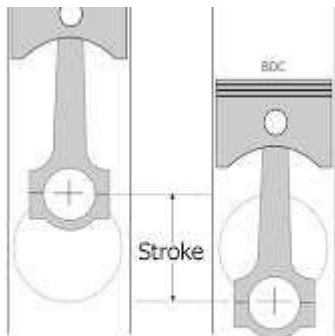

**Capacity (Displacement):** The total volume swept by all the pistons in the cylinders. Typically measured in cubic centimeters (cc) or liters (L).

$$\text{Capacity} = 4\pi \times \text{Bore}^2 \times \text{Stroke} \times \text{Number of Cylinders}$$

- **Horsepower (HP):** A unit of power, typically used to measure the output of an engine.
- **Top Dead Center (TDC):** The highest point the piston reaches in the cylinder.

- **Bottom Dead Center (BDC):** The lowest point the piston reaches in the cylinder.

#### d) Calculating the Capacity of a Given Engine:

- Use the formula: Capacity =  $(\pi/4) \times (\text{Bore}^2) \times \text{Stroke} \times \text{Number of Cylinders}$ .
- Example: If an engine has a bore of 80mm, a stroke of 90mm, and 4 cylinders, its capacity is:
  - ✓ Capacity =  $4\pi \times (80\text{mm})^2 \times 90\text{mm} \times 4$
  - ✓ Capacity = 1809557.37mm<sup>3</sup>
  - ✓ Capacity = 1.8L

📌 Learners should practice calculating engine capacity using different bore, stroke, and cylinder values.

#### e) Appreciating the Importance of Engines in Day-to-Day Life:

- Engines are essential for transportation, industry, agriculture, and many other aspects of modern life.
- They provide the power needed to operate a wide range of machines and devices.
- Understanding engine technology is crucial for maintaining and repairing these vital machines.
- Engines have allowed for the quick transportation of goods, and people.

## 4.2. Types of Engines

### Suggested Learning Experiences:

- **Peer Discussion:** Discuss the two main categories of engines based on combustion process.
- **Digital/Print Media Research:** Research the characteristics and examples of internal and external combustion engines.
- **Layout Drawing:** Draw a diagram of an external combustion engine, labeling its key components.
- **Comparative Analysis:** Compare and contrast internal and external combustion engines based on various criteria.

#### a) Explaining the Types of Engines According to the Combustion Process:

Engines are primarily categorized based on where the combustion of fuel takes place.

- ✓ **External Combustion Engines:** Combustion occurs outside the engine's working cylinder.
- ✓ **Internal Combustion Engines:** Combustion occurs inside the engine's working cylinder.

**b) Illustrating the Layout of External Combustion Engines:**

**External Combustion Engine Example: Steam Engine:**

- ✓ Fuel (e.g., coal, wood) is burned in a furnace to heat water.
- ✓ The heated water turns into steam, which is then used to drive a piston or turbine.
- ✓ Layout:
  - Furnace/Boiler: Where fuel is burned to heat water.
  - Steam Pipes: Carry the steam to the engine.
  - Cylinder and Piston (or Turbine): Where the steam's energy is converted to mechanical work.
  - Condenser (optional): Cools the steam back into water.

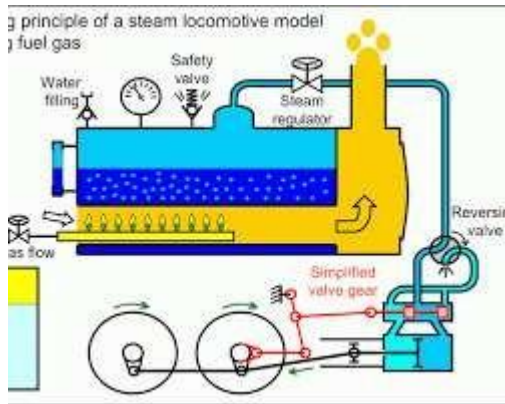

**c) Differentiating Between Internal and External Combustion Engines:**

Feature	Internal Combustion Engine	External Combustion Engine
Combustion Location	Inside the cylinder	Outside the cylinder
Fuel Type	Gasoline, diesel, natural gas	Coal, wood, nuclear, solar

Size	Generally smaller and more compact	Generally larger and bulkier
Components	Fewer moving parts	More complex system with boiler, condenser, etc.
Efficiency	Generally higher	Generally lower
Power Source	Chemical energy of fuel directly to mechanical energy	Chemical energy of fuel to thermal energy of water/steam to mechanical energy
Applications	Vehicles, generators, small machines	Power plants, some marine applications

#### d) Appreciating the Types of Engines Based on the Process of Combustion:

- Understanding the differences between internal and external combustion engines is crucial for selecting the appropriate engine for a specific application.
- Internal combustion engines are prevalent in transportation due to their efficiency and compactness.
- External combustion engines, while less efficient, are used in large-scale power generation.
- The study of these differences allows for better understanding of the evolution of engines, and allows for the development of new more efficient engines.

### 4.3. Classifications of Engines

#### Suggested Learning Experiences:

- **Digital/Print Media Research:** Research the various methods of classifying engines using the internet, textbooks, and automotive manuals.
- **Peer Discussion:** Discuss the different classification methods and their criteria.
- **Sketching:** Draw illustrations of different engine classes.
- **Classification Practice:** Practice classifying engines based on given criteria.

#### a) Explaining Methods of Classifying Engines in Power Mechanics:

Engines can be classified in several ways, including:

**Type of Combustion:**

- ✓ Internal Combustion (IC): Combustion occurs inside the cylinder.
- ✓ External Combustion (EC): Combustion occurs outside the cylinder.

**Type of Fuel Used:**

- ✓ Gasoline (Petrol) Engines.
- ✓ Diesel Engines.
- ✓ Natural Gas Engines.
- ✓ Propane (LPG) Engines.
- ✓ Electric Engines.

**Number of Cylinders:**

- ✓ Single-cylinder engines.
- ✓ Multi-cylinder engines (e.g., in-line, V-type, flat).

**Layout/Orientation of Cylinders:**

- ✓ In-line engines. ☐ V-type engines.
- ✓ Flat (horizontally opposed) engines.
- ✓ Radial engines.

**Cycle of Operation:**

- ✓ Two-stroke engines.
- ✓ Four-stroke engines.

**Reciprocating and Rotary Motion:**

- ✓ Reciprocating engines (piston engines).
- ✓ Rotary engines (Wankel engines, turbines).

**b) Categorizing Given Engines into Different Classes:****Examples:**

- ✓ A four-cylinder, in-line, gasoline, four-stroke engine.
- ✓ A V8, diesel, four-stroke engine.
- ✓ A two stroke single cylinder gasoline engine.
- ✓ A six cylinder horizontally opposed gasoline engine.

Learners should be able to identify the classification of an engine based on its specifications.

**c) Valuing the Different Classes of Engines:**

- ✓ Each engine class has its own advantages and disadvantages.

- ✓ The selection of an engine depends on the specific application and requirements.
- ✓ Understanding the characteristics of different engine classes is essential for selecting the appropriate engine.
- ✓ Engine classification allows for a better understanding of the strengths and weaknesses of different engine designs.

#### 4.4. Engine Components

##### Suggested Learning Experiences:

- **Online/Print Resources:** Research engine components using the internet, textbooks, and automotive manuals.
- **Visual Aids/Regalia:** Use diagrams, illustrations, and actual engine parts to identify components.
- **Sketching:** Draw illustrations of various engine components.
- **Brainstorming/Peer Discussion:** Discuss the functions of each engine component.
- **Measurement Practice:** Use appropriate instruments to measure engine components.

##### a) Identifying Components of an Engine:

- **Cylinder Block:** The main structure of the engine, containing the cylinders.  Image: An image of a cylinder block.



- **Cylinder Head:** Covers the cylinders and contains the valves and combustion chamber.
  - ✓ Image: An image of a cylinder head.

## Engine Head

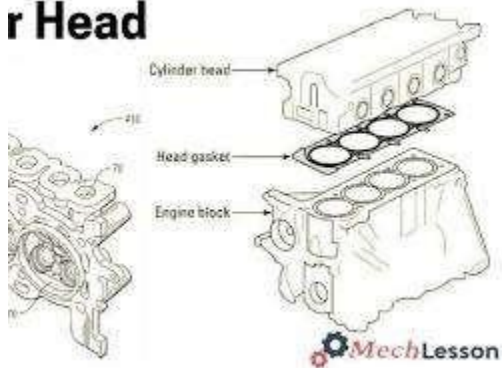

- **Piston:** A cylindrical component that moves up and down in the cylinder.  
✓ Image: An image of a piston.

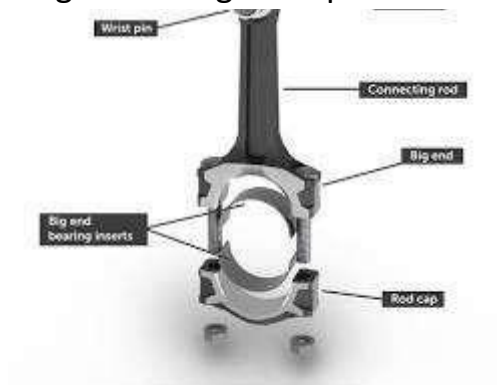

- **Connecting Rod:** Connects the piston to the crankshaft. 📄 Image: An image of a connecting rod.



- **Crankshaft:** Converts the linear motion of the pistons into rotary motion. 📄 Image: An image of a crankshaft.



- **Camshaft:** Controls the opening and closing of the valves.

✓ Image: An image of a camshaft.



- **Valves (Intake and Exhaust):** Control the flow of air and exhaust gases into and out of the cylinders.

✓ Image: An image of engine valves.



- **Rocker Arms:** Transfer the motion from the camshaft to the valves. ? Image: An image of rocker arms.



- **Rocker Cover:** Covers the rocker arms and valves.  
✓ Image: an image of a rocker cover.



- **Sump (Oil Pan):** Holds the engine oil.  
📷 Image: an image of an engine oil sump.



### b) Sketching Components of an Engine:

- Learners should be able to create accurate sketches of the key engine components.

### c) Describing Functions of Components of an Engine:

- **Cylinder Block:** Provides a rigid structure for the cylinders and other components.
- **Cylinder Head:** Seals the cylinders, houses the valves, and forms the combustion chamber.
- **Piston:** Compresses the air-fuel mixture and transmits the force of combustion to the connecting rod.
- **Connecting Rod:** Connects the piston to the crankshaft, converting linear motion to rotary motion.
- **Crankshaft:** Converts the linear motion of the pistons into rotary motion, which drives the vehicle.
- **Camshaft:** Controls the timing of the valves, ensuring proper intake and exhaust flow.
- **Valves:** Control the flow of air and exhaust gases into and out of the cylinders.
- **Rocker Arms:** Transfer the motion from the camshaft to the valves.
- **Rocker Cover:** Protects the rocker arms and valves from debris and oil leaks. **Sump:** Stores and supplies engine oil for lubrication.

### d) Performing Measurements on Engine Components:

- **Journal Measurement:** Use a micrometer to measure the diameter of the crankshaft journals.
- **Cylinder Bore Measurement:** Use a cylinder bore gauge to measure the diameter of the cylinder bore.
- **Clearances Measurement:** Use feeler gauges to measure clearances between components, such as valve clearances.
- **Piston Ring Gap Measurement:** Use feeler gauges to measure the gap in the piston rings.

### e) Appreciating the Need for Engine Components:

- ✓ Each engine component plays a crucial role in the engine's operation.
- ✓ Proper functioning of all components is essential for engine performance and reliability.
- ✓ Understanding engine components is essential for engine maintenance and repair.